

**1. Proportional Micro Joystick Technical Information**

**3. Installing Electronics Properly, Grounding Issues**

**2. Variable Voltage Modules Tips and Users**

**4. Single Axis Driver Setup and Calibration Guide**

\*Please click the topic lists here to be taken directly to the specific page.

## 1. Proportional Micro Joystick Technical Information

### “J” Series handle with Micro Joystick



### Description

The Micro Joystick is a miniature Proportional Hall Effect joystick with only 3 moving parts. Designed for exposed application, this simple thumb operated joystick provides an additional 2 axis of proportional control within a control grip faceplate.

### Part #: MJS-P2

Operation: Dual axis, spring return  
Input Voltage: 5 VDC @ 30ma  
Output: 0.5 - 2.5 - 4.5 VDC (+/- 0.3)  
Rating: IP-66 (above panel)  
Travel: +/- 14°

### “L” Series handle with 1 Micro Joystick 4 on/off switches

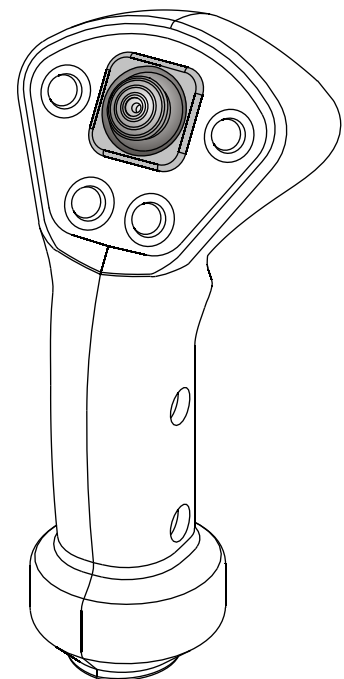

### Dimensions

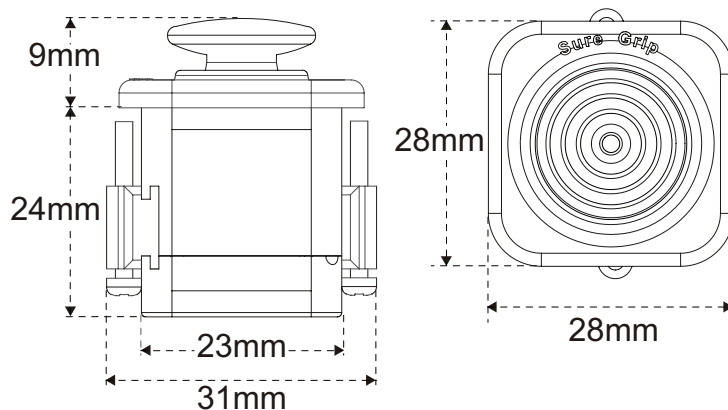

## [1. Proportional Micro Joystick Technical Information](#)

## [2. Variable Voltage Modules Tips and Users](#)

## [3. Installing Electronics Properly, Grounding Issues](#)

## [4. Single Axis Driver Setup and Calibration Guide](#)

\*Please click the topic lists here to be taken directly to the specific page.

## 2. Variable Voltage Module Tips and Users

The Sure Grip Controls Variable Voltage Module assembly is a thumb or finger operated signal level proportional input device.

There are 2 pieces to each Module assembly: the Sensor Module that houses the Hall sensor and the finger/thumb actuator that hold the magnet.

Sure Grip Controls offers three Actuators for these Modules; Rocker, Flex Button and Trigger. The V2 Module assembly can be used anywhere speed control of hydraulic a function is desired. Typical applications would be Thumb controls, Rotating controls (grapples etc), and Speed controls.

As stated above, these proportional controls are *signal level* devices. This means they will signal a computer or driver card when the actuator is moved, and then the computer or driver card will process the signal and control the hydraulic valve. Sure Grip Controls manufactures a variety of Driver Cards for your convenience.

In the past, proportional control was obtained by the use of potentiometers. These are complex mechanical devices with many moving parts. Sure Grip Controls uses non-contact magnetic technology. This trouble-free system has only one moving part (actuator), which we have tested to well beyond 10 million operations!

There are a number of advantages to using proportional controls: They reduce or eliminate shock loading of the hydraulic system: and, flow restrictors are not required - this cuts down heat build up, reduces operator fatigue, less machine vibration, and reduces or eliminates bucket damage caused by thumb contact.

If you are looking to upgrade your existing machine controls to proportional, there are a few things to consider. Standard switched (on/off) solenoid valves will not work proportionally. The switched valve coils will have to be replaced with PWM Proportional valve coils. Most hydraulic valve manufacturers offer either switched (on/off) or PWM Proportional valve coils. Check with your valve supplier for proportional coils. If you are installing a new attachment, be sure to specify which functions you want to control proportionally. Order the valve with PWM Proportional coils for those functions.

With the many attachments available for machinery today, we have found that most machines are being used with multiple attachments. Sure Grip Controls has developed driver cards with this in mind. Our SDB-P1 driver card can be programmed to control up to three proportional attachments with different flow requirements. A toggle switch is installed to switch between attachment programs.

## 1. Proportional Micro Joystick Technical Information

## 2. Variable Voltage Modules Tips and Users

## 3. Installing Electronics Properly, Grounding Issues

## 4. Single Axis Driver Setup and Calibration Guide

\*Please click the topic lists here to be taken directly to the specific page.

### 3. The Importance of Proper Grounding to Electronic Controls

If you have ever experienced a car that would start sometimes but not others, it was likely the starter and the electronics were not grounded to the battery properly. This is a common problem that can exhibit itself through a number of different behaviors. Sure Grip electronics will typically show the following symptoms if proper grounding is not installed:

- Won't work.
- Intermittent operation.
- Will not calibrate
- Incorrect dead band.
- Incorrect voltage output.

If a device shows any of these symptoms the ground wiring should be inspected. The best way to ensure that the device is grounded adequately is to measure the impedance (ohms) from the device ground to the battery neg. Terminal on the equipment with a multimeter.

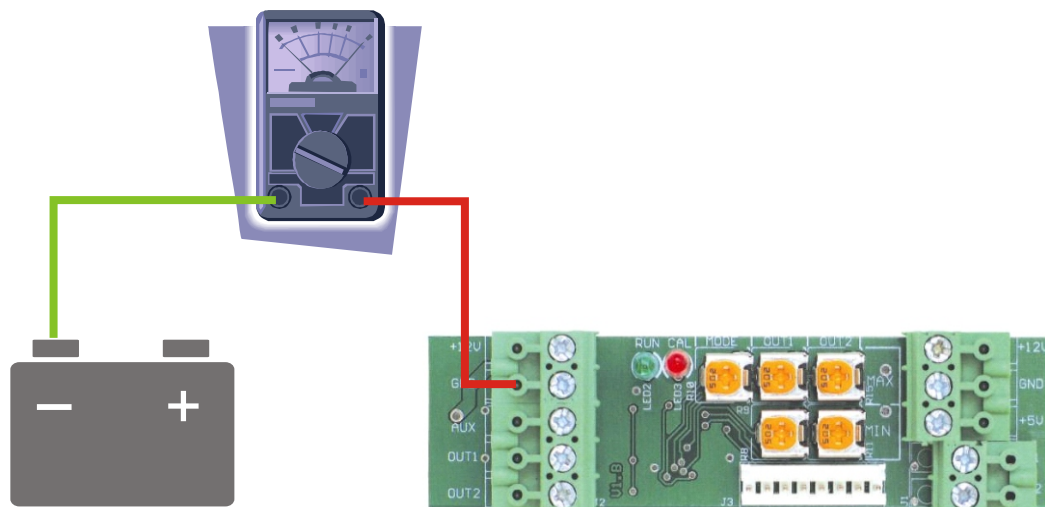

Measuring the ground this way with the multimeter should result in a reading of 0.05 ohms or less. If the impedance is found to be higher or no connection is found inspect the ground wiring that is connected to the device and readjust as necessary and recheck with the multimeter.

## 1. Proportional Micro Joystick Technical Information

## 2. Variable Voltage Modules Tips and Users

## 3. Installing Electronics Properly, Grounding Issues

## 4. Single Axis Driver Setup and Calibration Guide

\*Please click the topic lists here to be taken directly to the specific page.

### 4. Single Axis Driver Setup and Calibration Guide

The Single axis driver board is shipped from Sure Grip controls with a factory configuration. To match the configuration of the final application the following setup producer is require.

Before proceeding with setting the operating values make sure the board is installed with power and ground and that the driver board outputs are wired to the solenoids that will be operated.

#### Step1:

Apply power to the board and observe that the RUN light (green) comes on. Turn the Mode potentiometer CCW (counter clockwise) until the CAL light (red) comes on.

#### Step2:

Adjust the output potentiometers to the appropriate operating output. Turning the potentiometer CCW will decrease the PWM output while turning CW(clockwise) will increase the PWM output. Test the machine operation while making adjustments to ensure correct operation.

#### Step3:

When the output values are set to the correct operation turn the MODE potentiometer CW(clockwise) until the RUN light (green) comes on.

